

## ROTARY FIXTURE

*Allows a VersaLaser™ to be quickly reconfigured to engrave and cut cylindrical objects.*



**For VL-200**

Size: 19"W x 5.25"D x 5"H

Weight: 9 lbs.

**For VL-300**

Size: 27"W x 5.25"D x 5"H

Weight: 10 lbs.

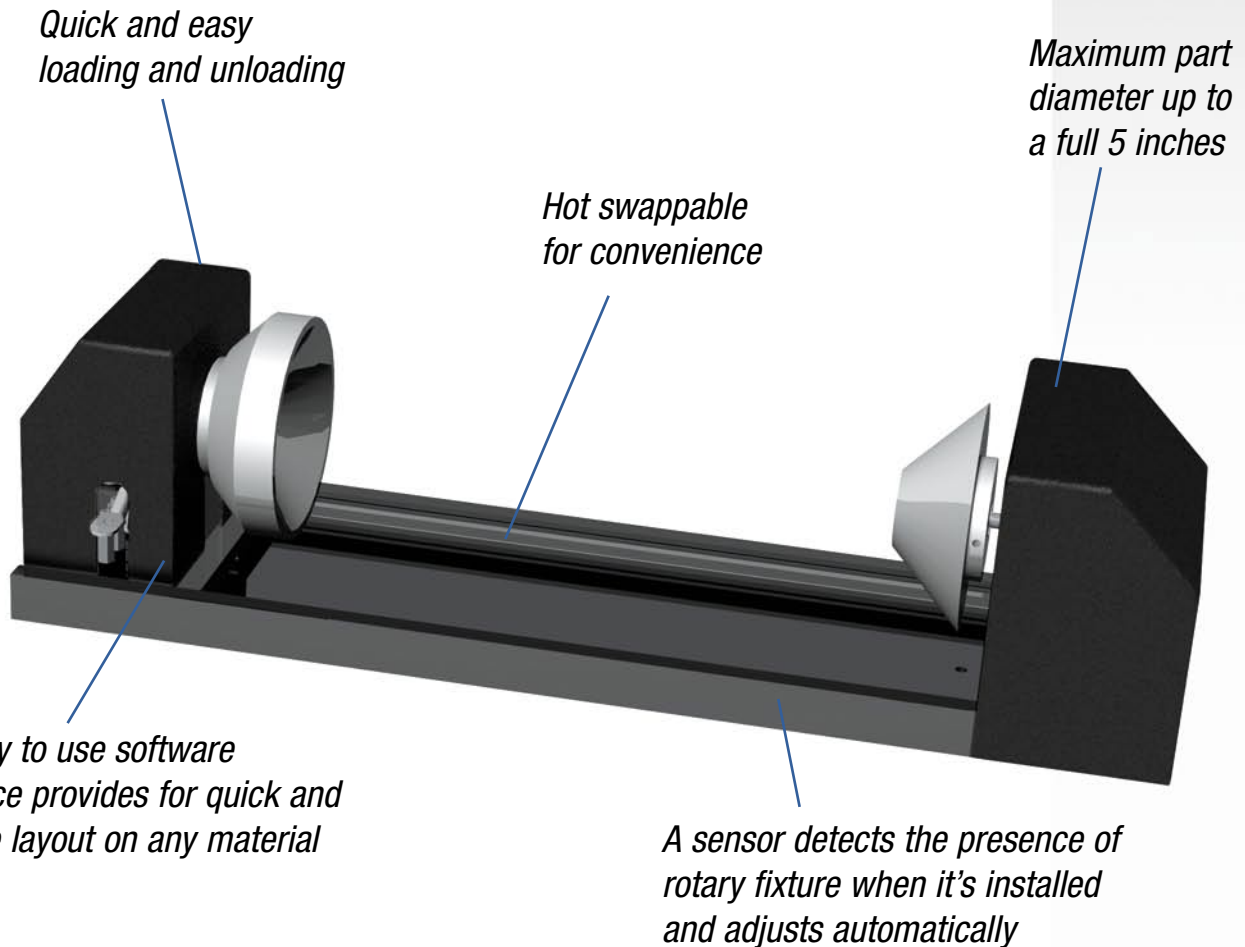

**UNIVERSAL**  
LASER SYSTEMS INC.